

PRÉ-FURAÇÃO NO ARO, USANDO O TEMPLATE
PRE-DRILL THE FRAME, USING THE TEMPLATE /
PERFORAR PREVIAMENTE EL MARCO, USANDO LA PLANTILLA

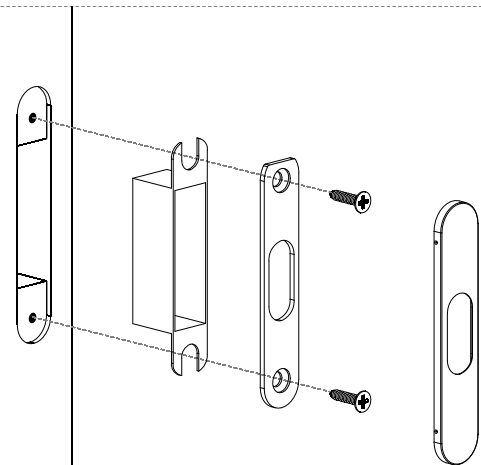

J. Neves & Filhos
Comércio e Indústria de Ferragens, S.A.

Rua das Mimosas, 849 / 851
Zona Industrial das Mimosas
4510-329 Gondomar - PORTUGAL

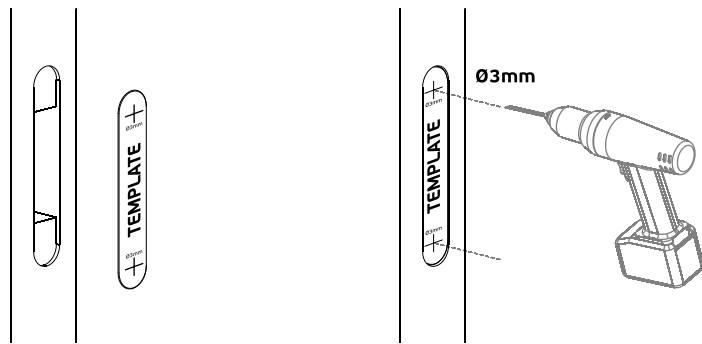
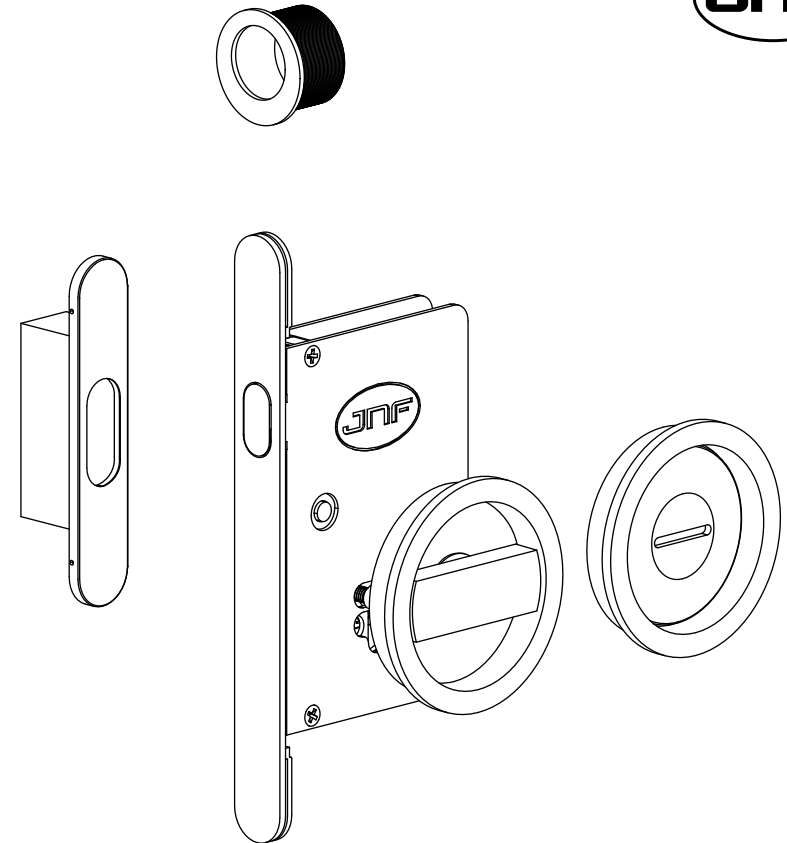

IN.20.937/ IN.20.938/ IN.20.939/ IN.20.940

FECHADURA PARA PORTAS DE CORRER
LOCK FOR SLIDING DOORS /
CERRADURA PARA PUERTAS CORREDERAS



**ENTALHE NA PORTA /
DOOR CUT / TALADRO EN LA PUERTA**

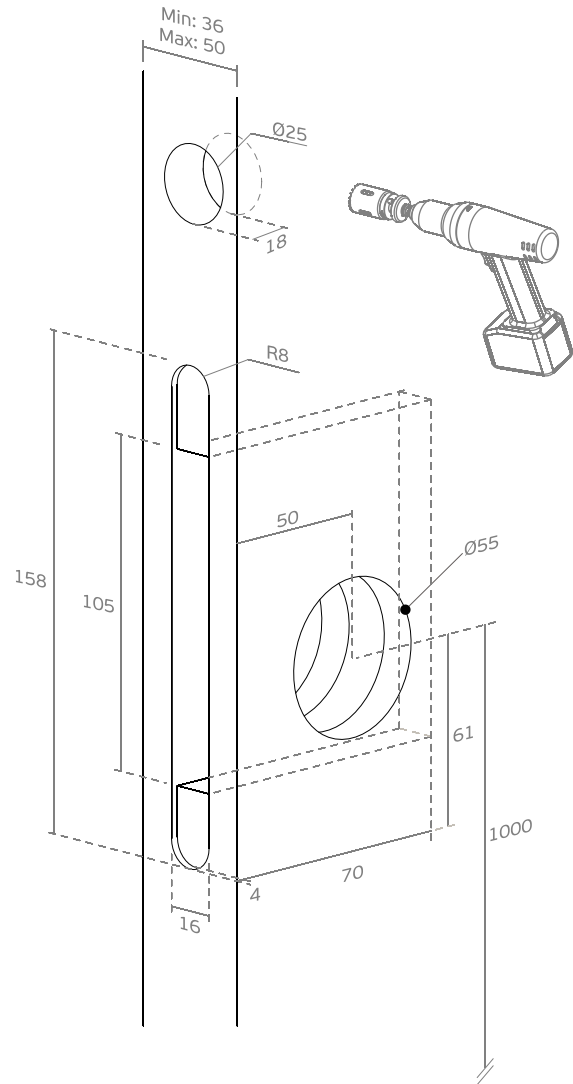

(Unidades/ Units: mm)

**ENTALHE NO ARO /
FRAME CUT / TALADRO EN EL MARCO**

